



Take care of your batteries

Powercharge Battery Optimizer is an innovation within battery balancers, which efficiently equalizes and maintains batteries in series-connected strings.

The Optimizer, which is both efficient and easy to use, equalizes the batteries during charge, discharge and idle mode.

It is an efficient design, which allows equalization to be accomplished by transferring energy from the strongest battery to the weakest, with minimal energy loss.

The Optimizer can be used on all serial battery systems, irrespective of the configuration, and is easy to install.

The efficiency of the equalization technique has been documented. Independent tests show significant improvements to both the life of the battery and its capacity.

The capacity of the batteries depends largely on the capacity of the weakest battery in the string. Powercharge Battery Optimizer ensures that all batteries in the string are equalized.

The life of the battery is extended as both over and undercharging are prevented. Equalization with Powercharge Battery Optimizer reduces the risk of the incorrect charging of batteries, thus extending the life of the battery.

Unlike standard shunt equalizers, Powercharge Battery Optimizer operates during charge, discharge and idle mode.

Powercharge Battery Optimizer is an efficient equalizer which transfers energy between batteries with minimal energy loss, unlike standard shunt equalizers which dissipate excess energy by converting it to heat.

The Powercharge Battery Optimizer is designed to be used regardless of the number of batteries in the string.

- more than battery charging

Technical data

Typ	Powercharge Battery Optimizer
Battery nominal voltage	24 V (2 x 12 V)
Optimizing current	0 – 5 A
Quiescent current	< 0.5 mA
Dimensions	80 mm x 38 mm x 21 mm
Protection	Reverse polarity protection Under voltage lock out (10V)

Materials and specifications are subject to change without notice

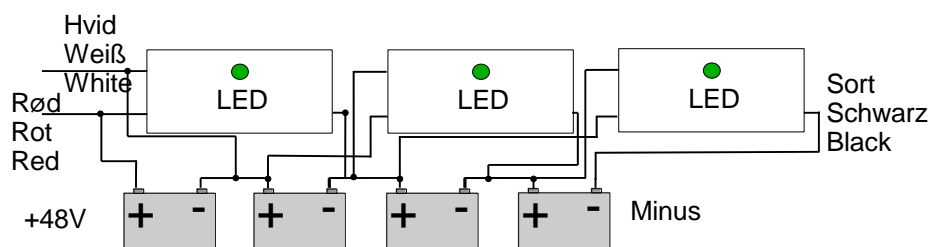
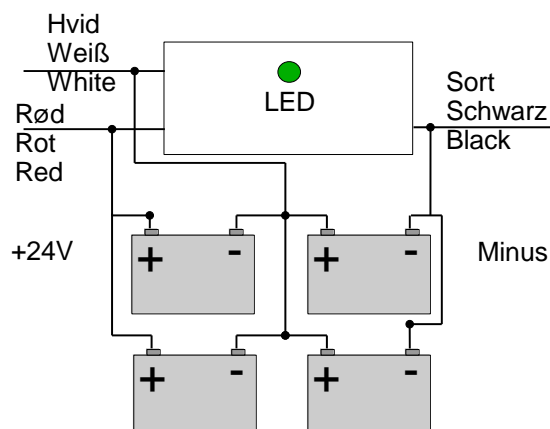
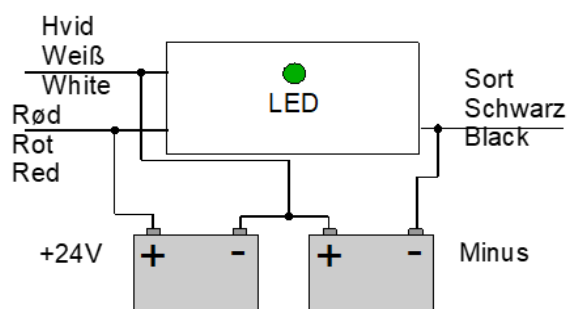

Head Quarter:
Swede Electronics AB
Fabriksvägen 8, SE-786 33 Vansbro
Tel.: +46 281-304 00

Contact:
Web: www.swedelec.se
E-Mail: info@swedelec.se

Sales Office Europe:
Swede Electronics A/S
Birkmosevej 13B, DK-6950 Ringkøbing
Tel.: +45 76 20 66 66